

A	B	C1	C2	C3	D
1	S503-5005	134	50	50	1/3
2	S515-0005	555	240	15	2/3
3	S515-0014	728	555	19	2/3
4	S515-1025	935	413	50	1/3
5	S515-1026	935	413	50	1/3
6	S515-1027	786	391	15	1/3
7	S515-1028	786	391	15	1/3
8	S515-2009	1862	438	28	3/3
9	S515-3007	560	362	15	2/3
10	S515-3020	1713	373	15	3/3
11	S515-5207	1713	50	19	3/3
12	S515-9007	804	574	2.5	2/3
13	S515-9008	804	575	2.5	2/3
14	S515-9009	804	574	2.5	2/3
15	WSP-939	522	358	2.5	3/3
16	ZK3-5074	511	167	15	2/3
17	ZK4-503	350	180	12	2/3
18	ZK4-504	350	180	12	2/3

3x

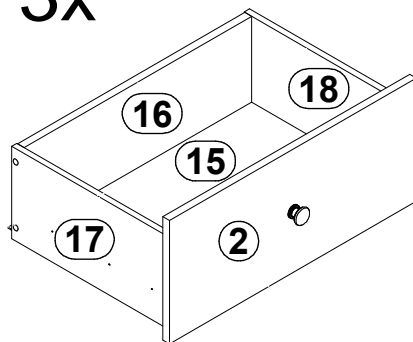

3x 350 mm z1	3x M4x22 mm j30	3x Ø3.5x16 mm t35	3x Ø3.5x10 mm p25	3x Ø3.5x10 mm p35	
1x z1	3x M4x22 mm j30	8x Ø2.9x16 mm p55	8x 20x13x3.9 L n108	6x d41.2	
4x b91	4x Ø3.5x35 a203	2x M4x25 mm j8	6x k1	17x l1	
8x Ø5x17 mm d1	5x c475	9x l2	42x Ø3.5x16 mm p38	8x Ø3.5x15 mm p51	
6x w210/1	4x Ø6.3x15 mm d4	6x Ø7x50 mm e1	12x Ø15x12 mm #16 r1	24x 20/11 r42	8x Ø16 s2
6x L-350 mm w210/2	6x Ø6x30 mm f9	12x Ø6.5x40 mm f25	12x Ø12x10.5 mm #12 r15	16x Ø8x30 mm f1	36x Ø3.5x12 mm p140
		2x Ø10x50 mm f35	2x Ø5x60 mm p17	4x Ø3.5x16 mm p38	2x Ø8x21x15 L n14/2

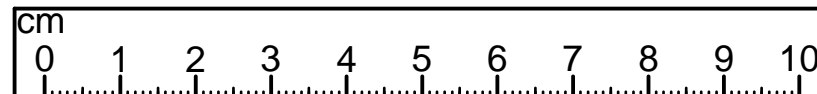

1 

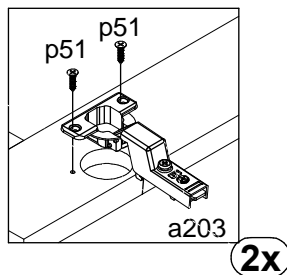
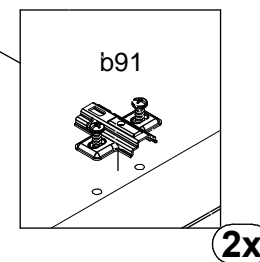
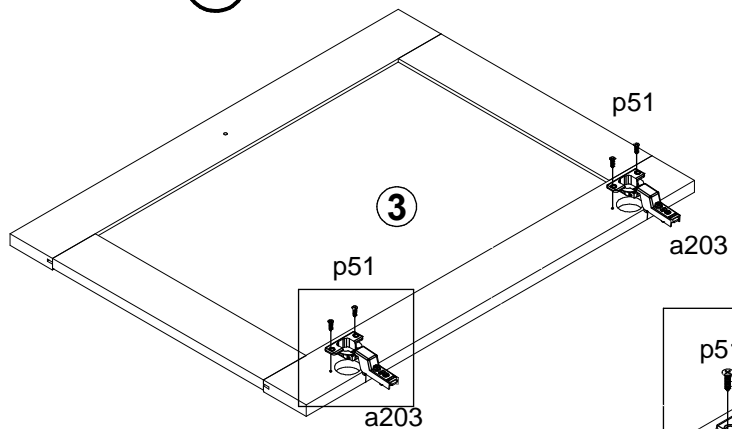
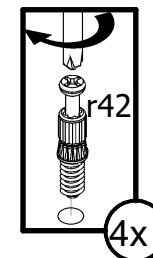
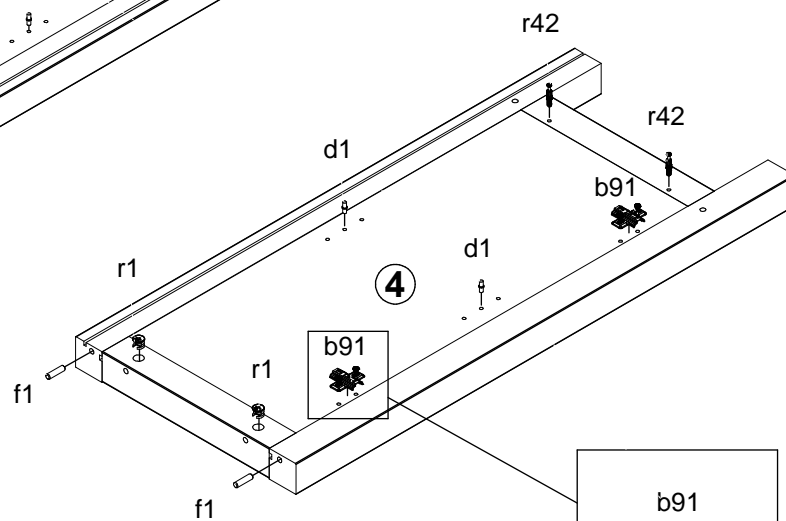
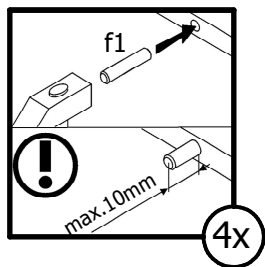
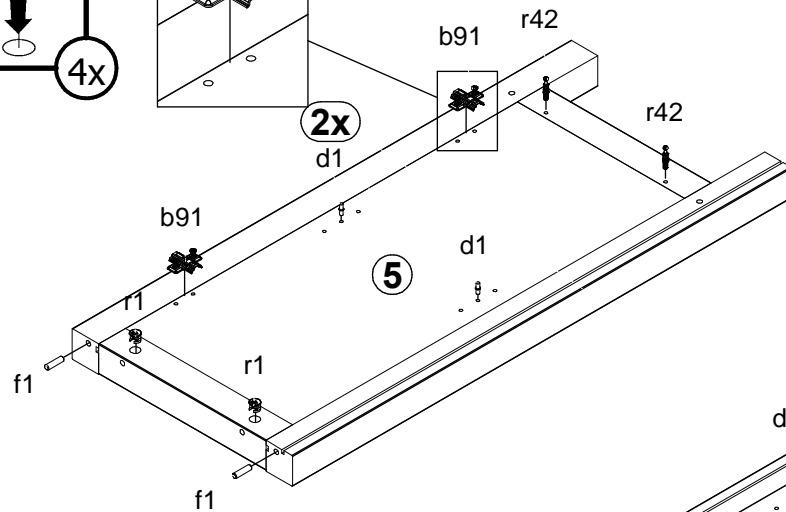
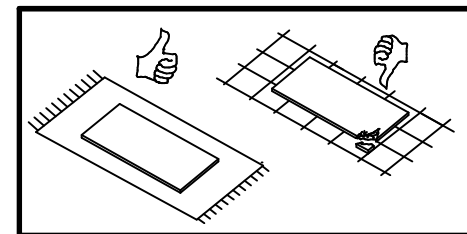
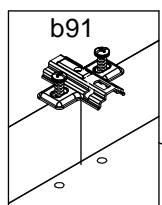
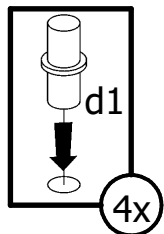
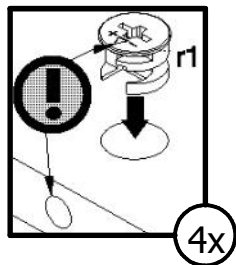

1

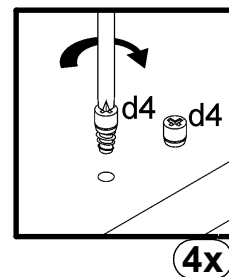
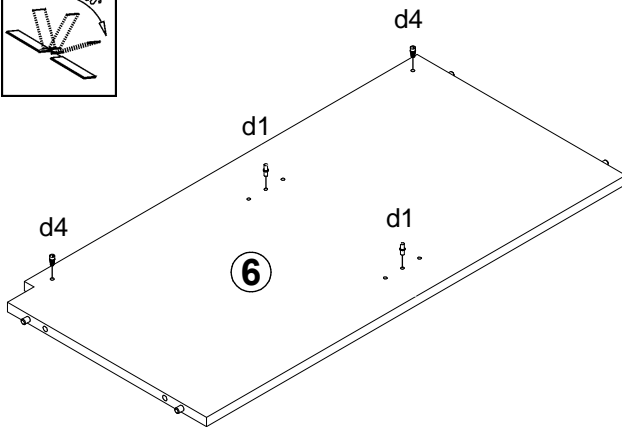
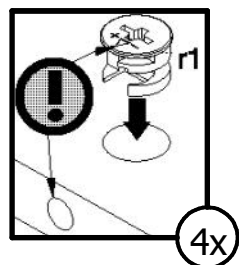
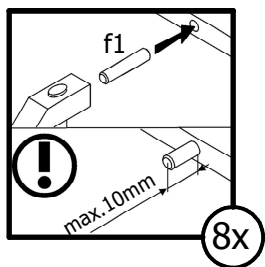
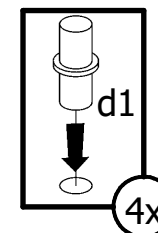
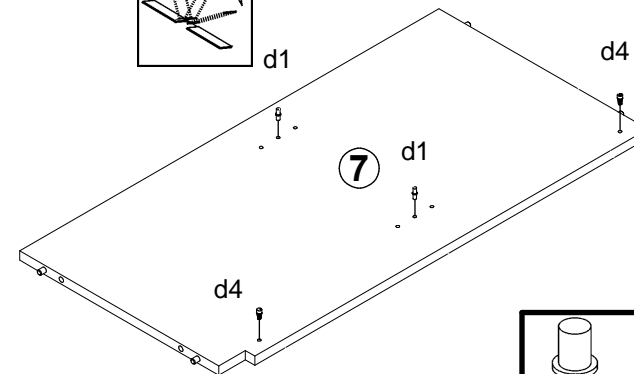
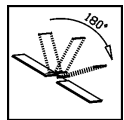
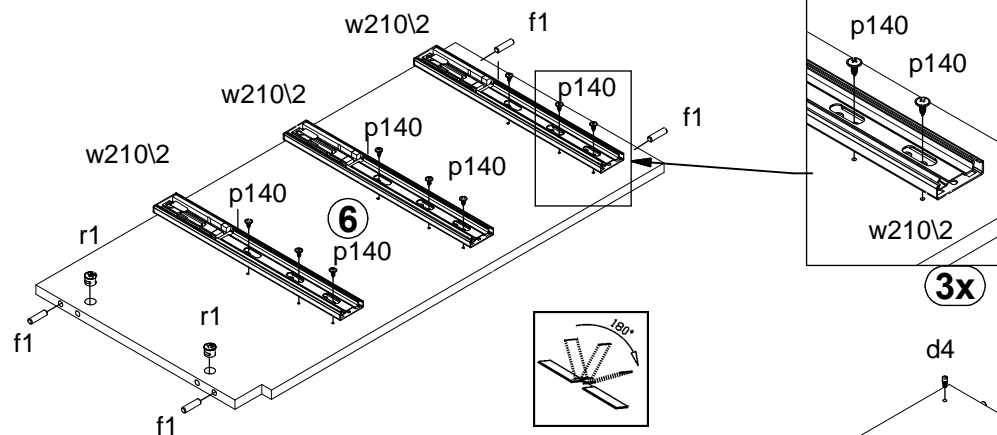
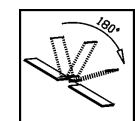
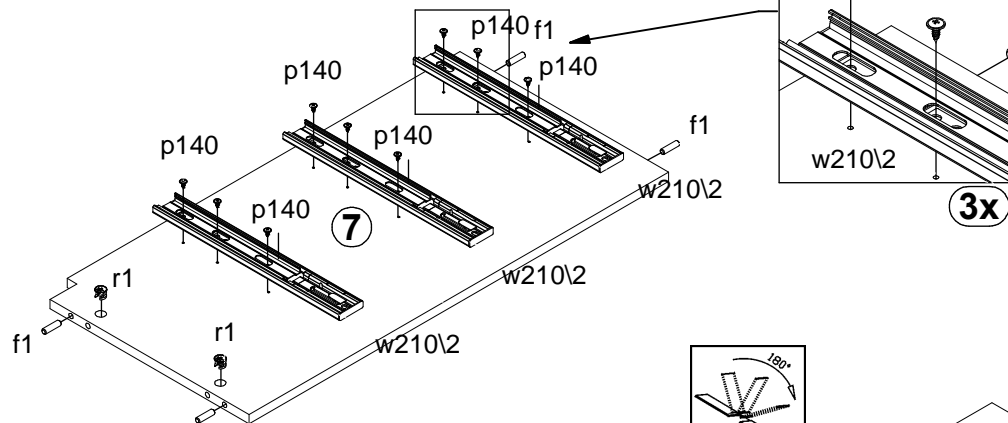
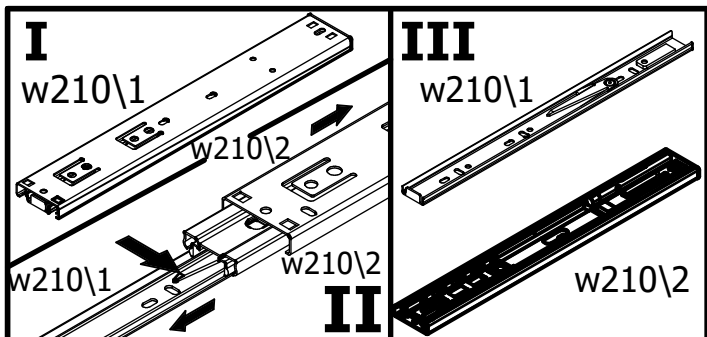

1

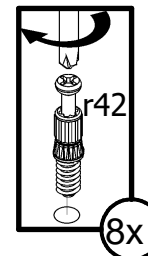
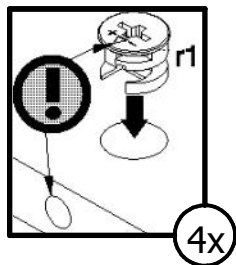
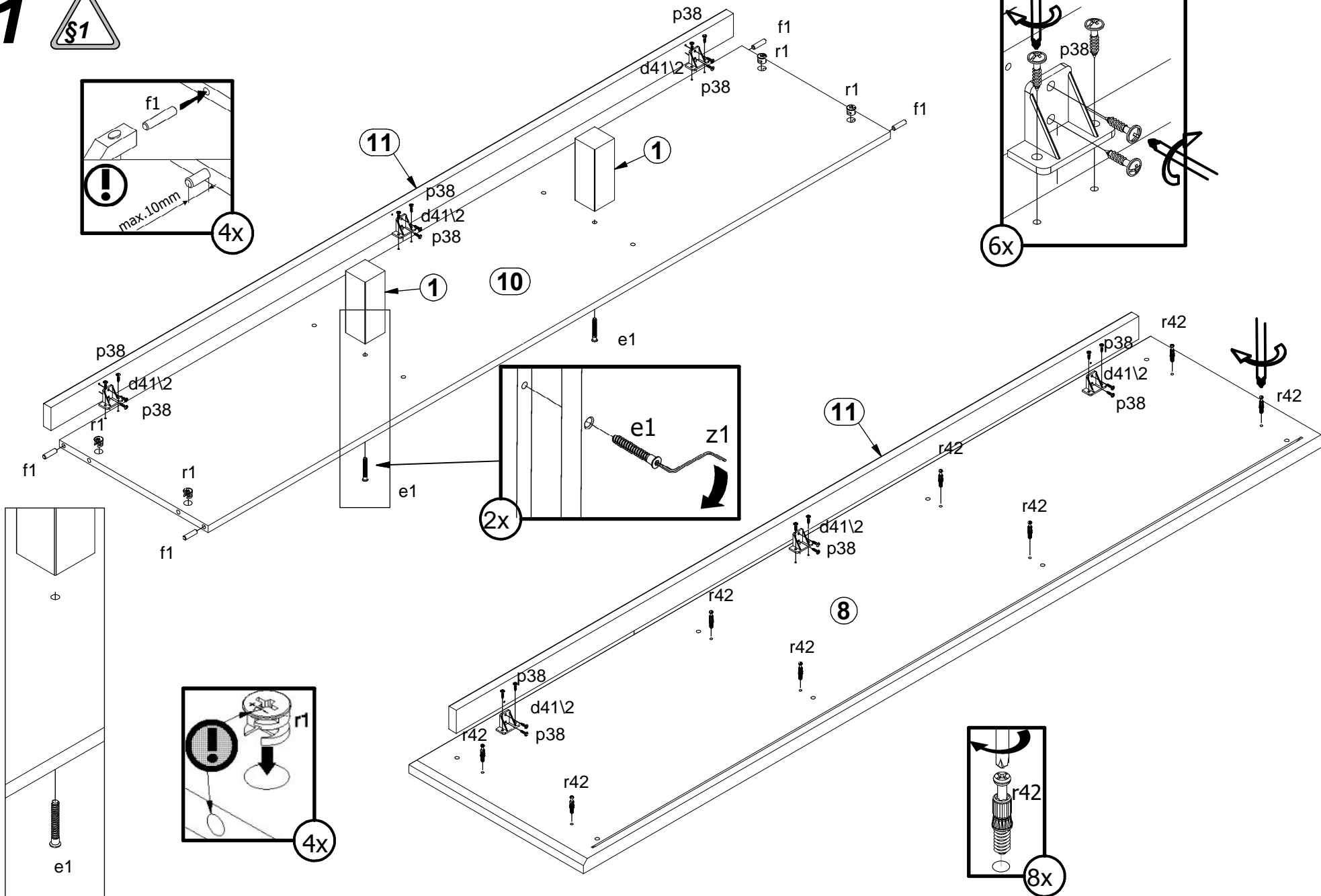
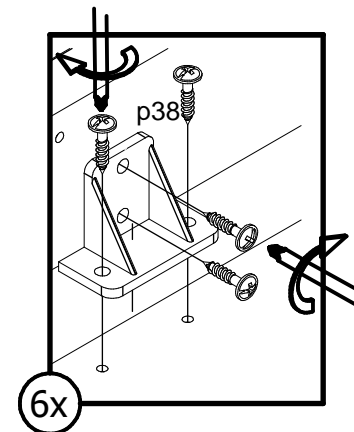
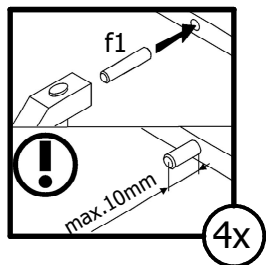

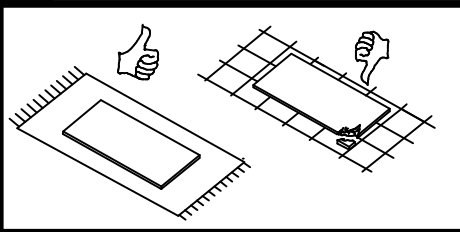

2

3

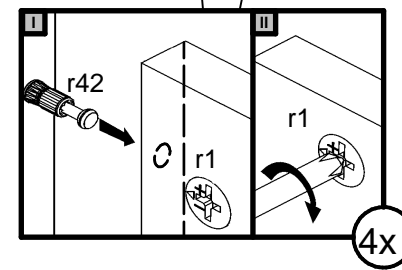
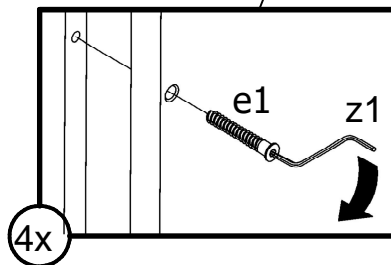
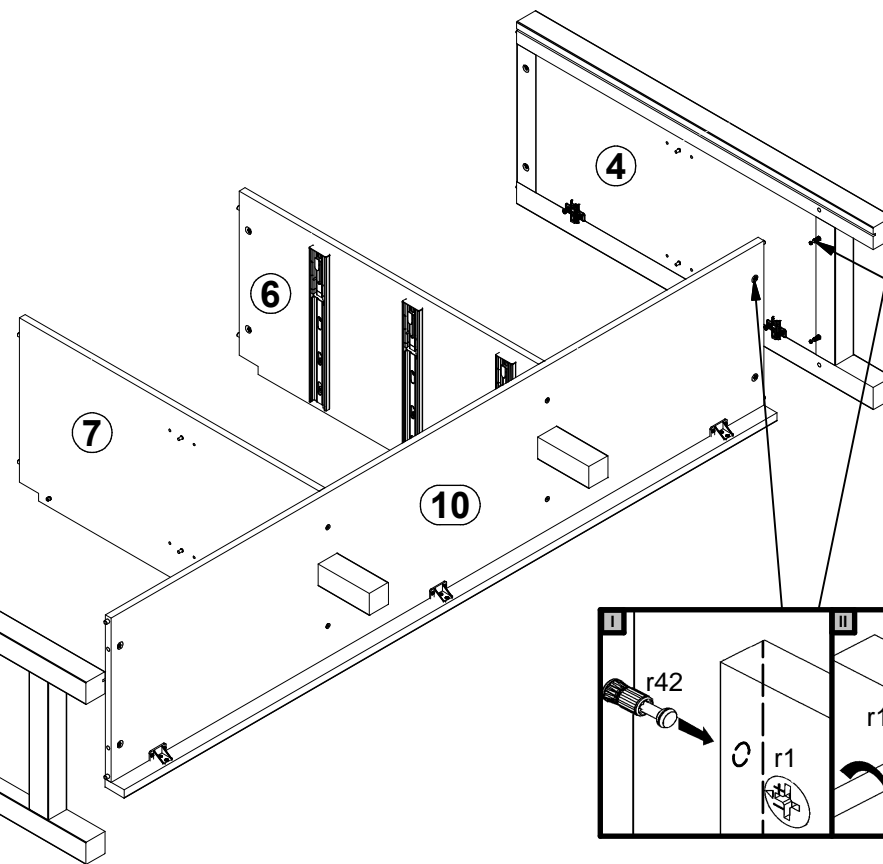
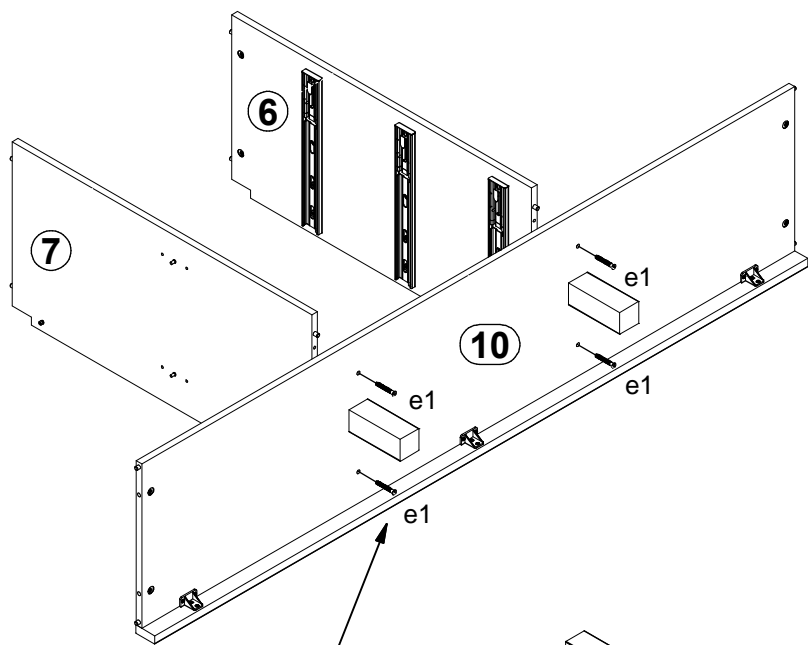



4

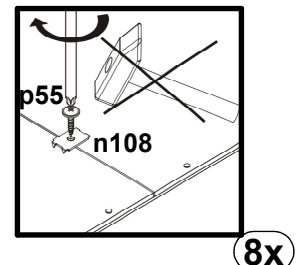
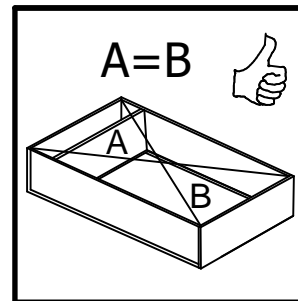
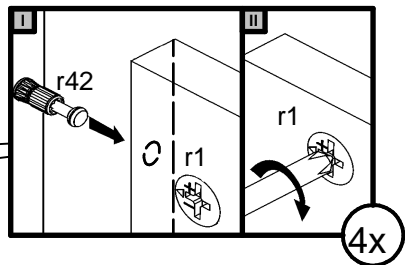
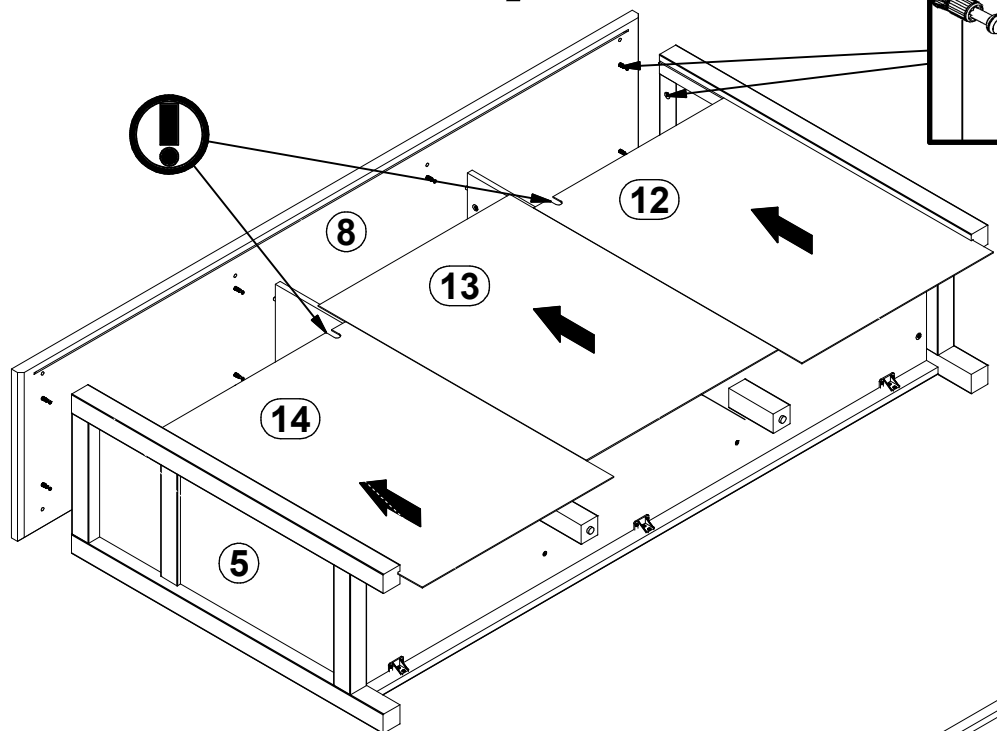

5

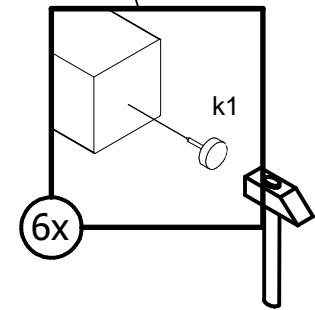
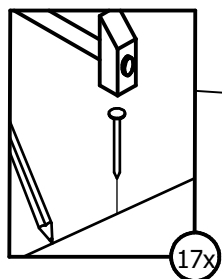
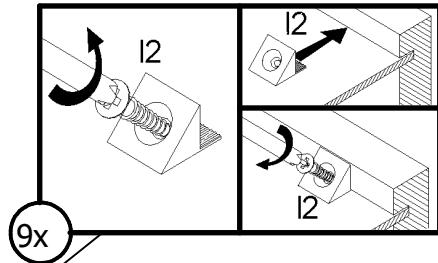
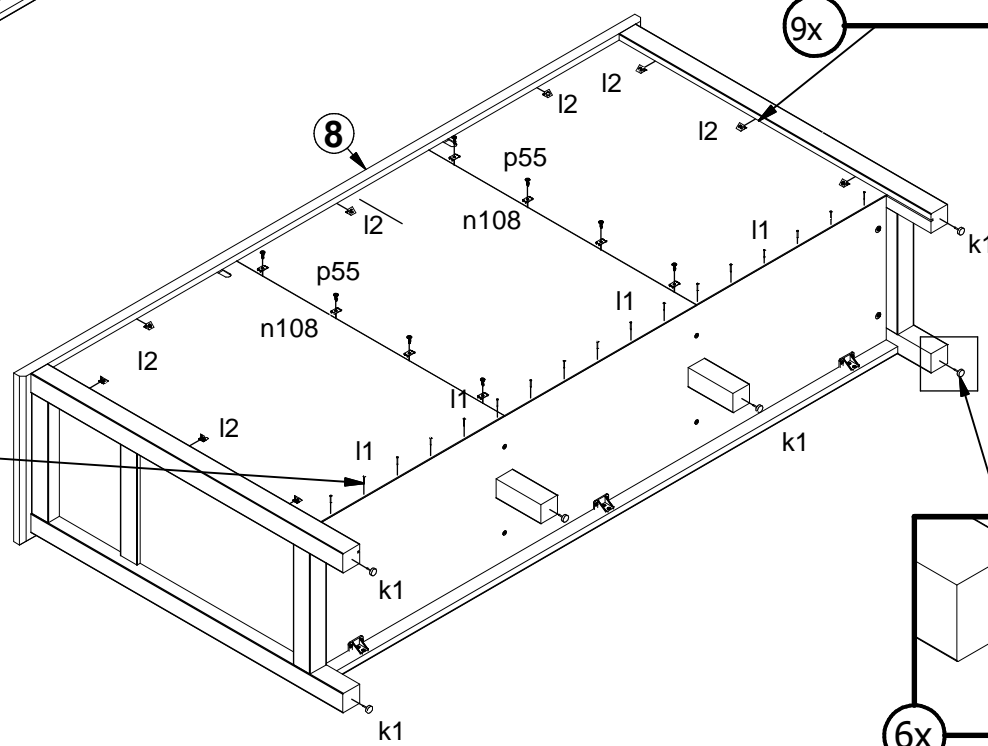

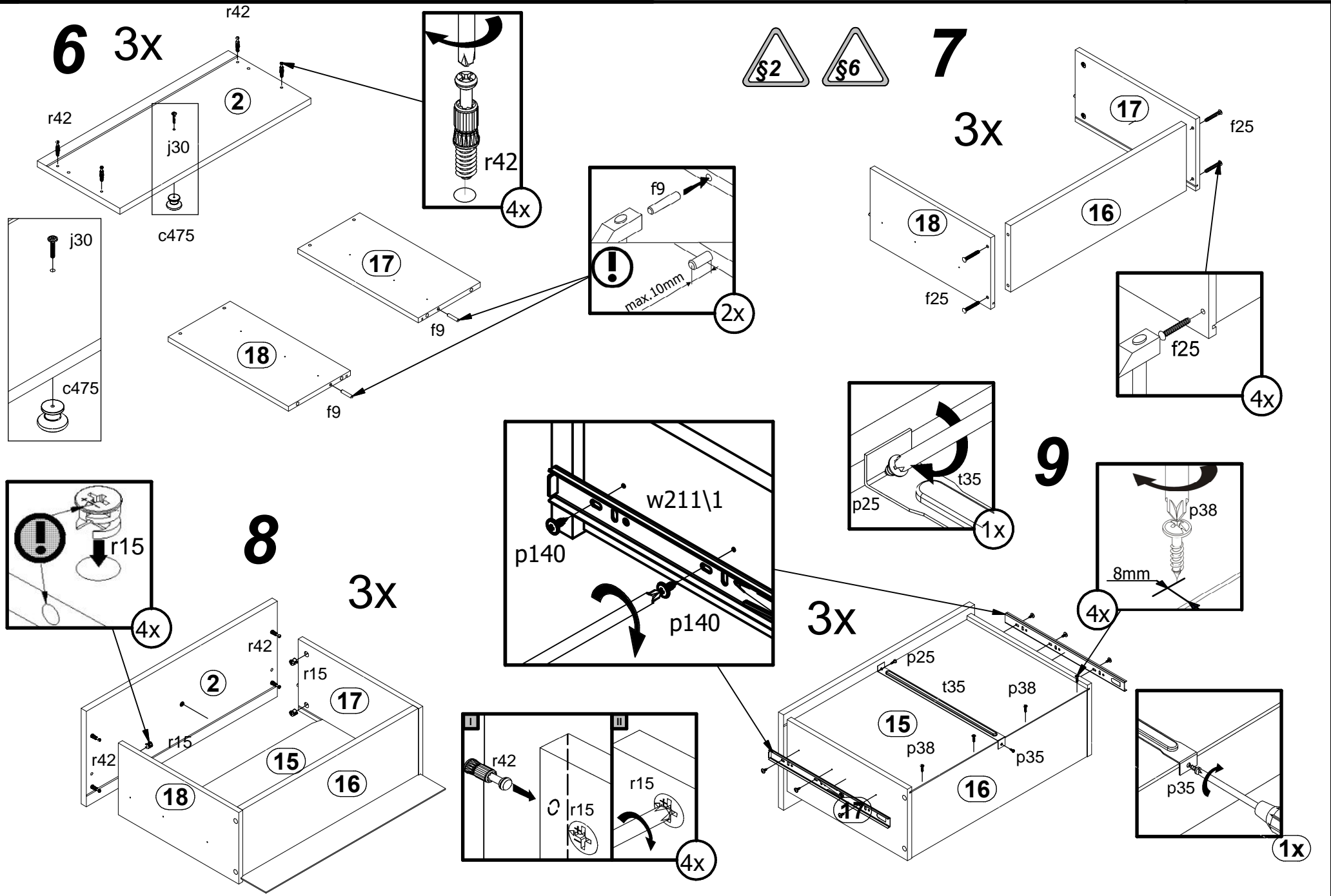

10

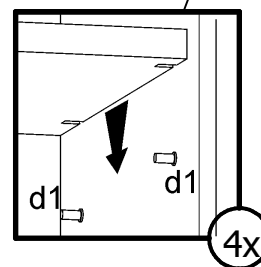
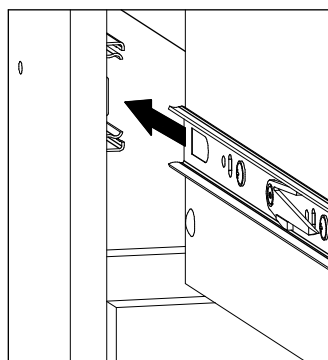
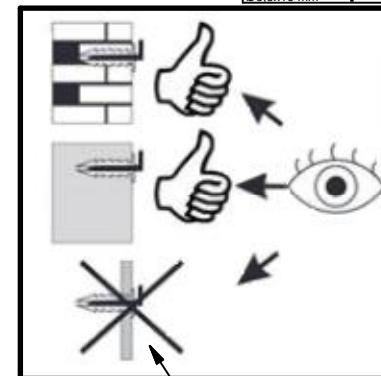
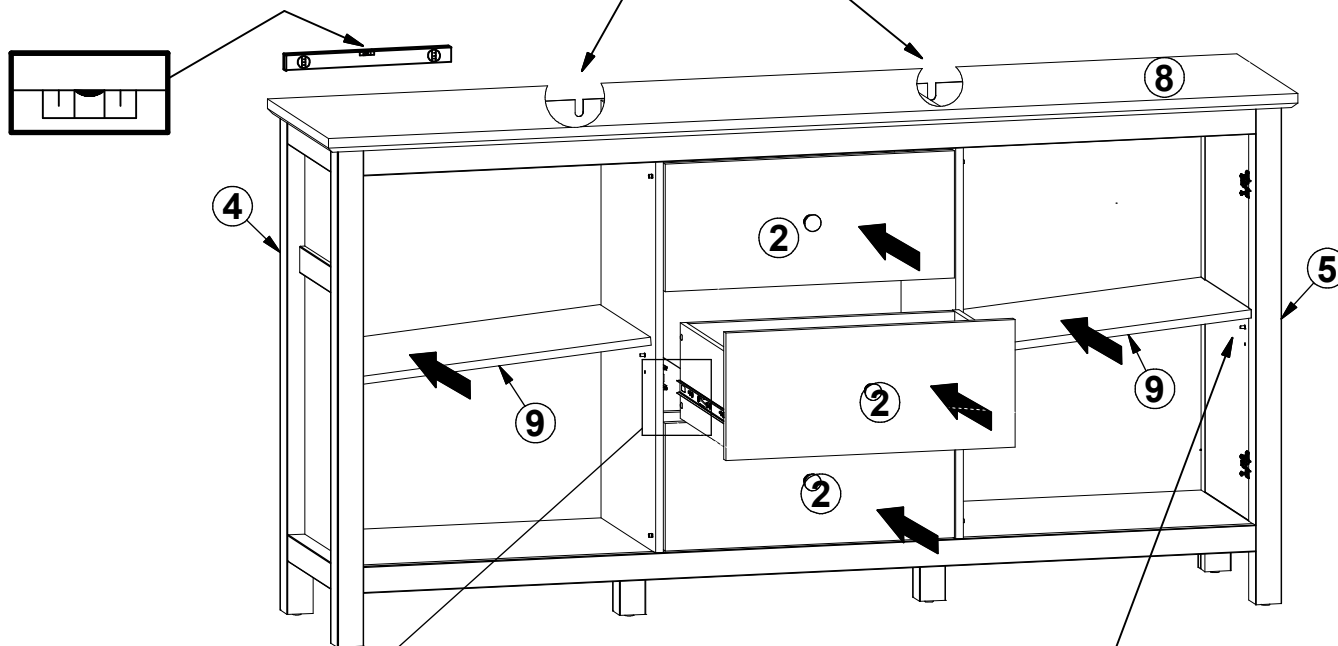
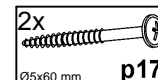
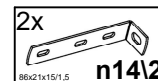
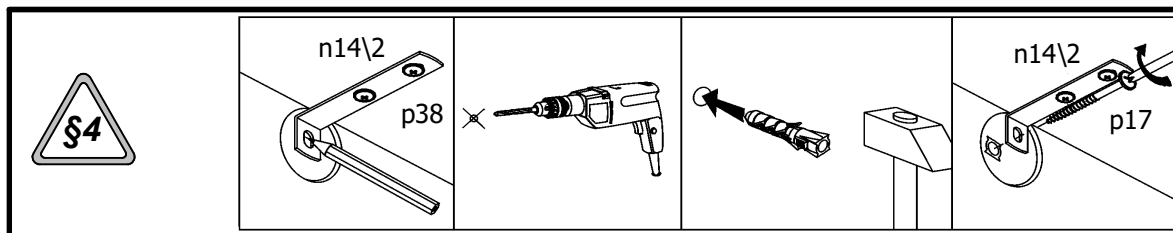

11

