









Pars check list

Assembly Sheet

Dorka

NO	Particulars	QTY
01	Headboard	1
02	Footboard	1
03	Wooden legs for headboard	2
04	Wooden legs for footboard	2
05	Side rail	2
06	Transverse tubule	2
07	Central rail	1
08	post	4
09	bentwood slats	28

Hardware List

A		C		E		G	
M6 x 25MM	16 PCS	M6 x 35MM	2 PCS	4 x 4MM	2 PCS	CENTER SLAT STOPPER	14 PCS
B		D		F		H	
M6 x 60MM	2PCS	M6对接螺母	4 PCS	SIDE SLAT STOPPER	28 PCS	tube plug	Ø19
							4 PCS
						I	
						M6 x 30MM	4 PCS

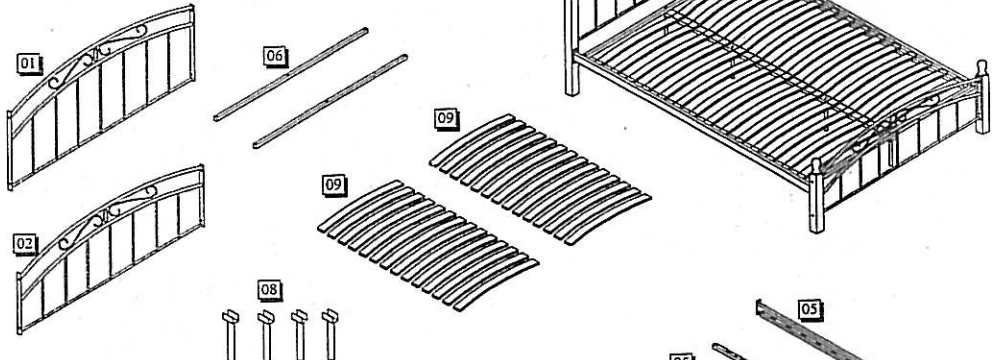



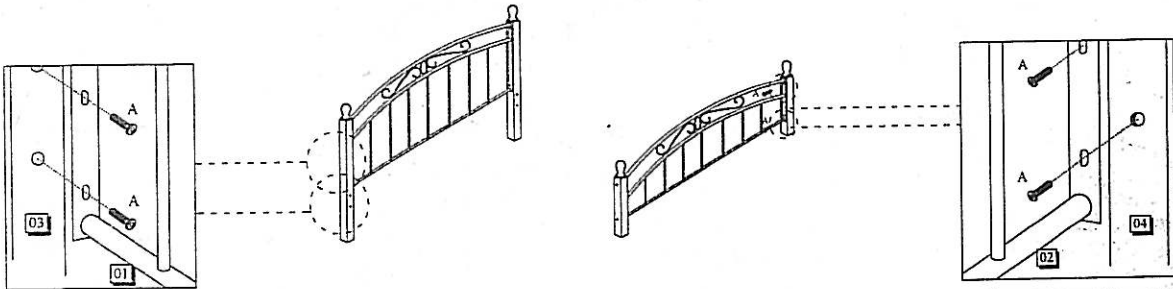



1: Joining the wooden legs to the headboard and footboard

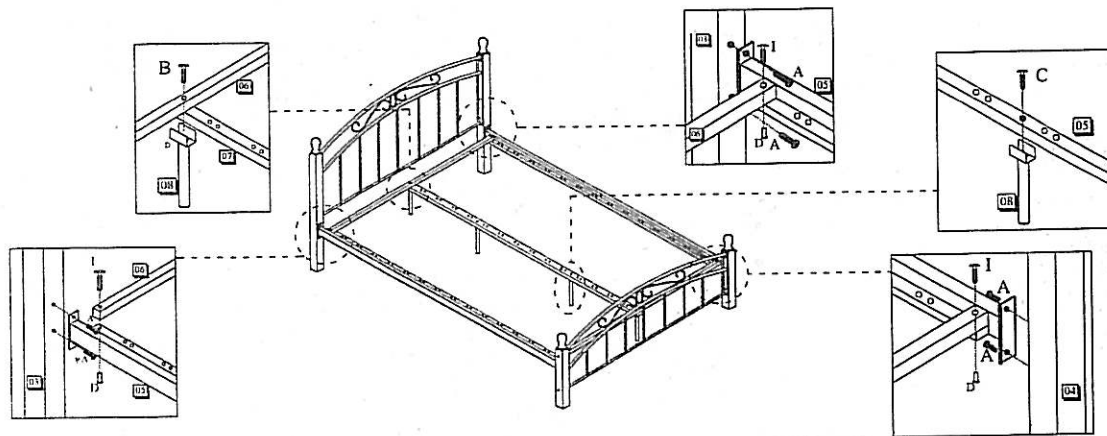

A	
M6 x 25MM	8PCS



2: Connecting the side rail to the headboard and footboard, and attaching the transverse tubule to it as below

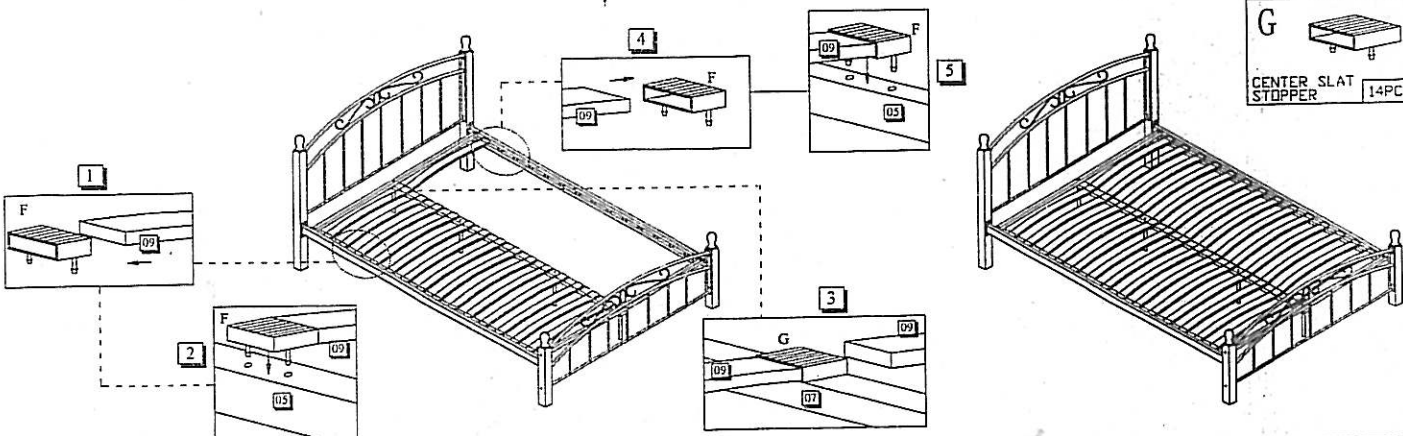

A	
M6 x 25MM	8PCS
B	
M6 x 60MM	2PCS
C	
M6 x 35MM	2 PCS
D	
对接螺母	4 PCS
I	
M6 x 30MM	4 PCS

3: Fitting the sprung slats and post



F	
SIDE SLAT STOPPER	28 PCS
G	
CENTER SLAT STOPPER	14PCS